

Tetra® PowerStrip Snap DS

LED Lighting System

24
Volt

GEDS71-3, GEDS65-3, GEDS57-3, GEDS50-3,
GEDS41-3, GEDS32-3



BEFORE YOU BEGIN

Read these instructions completely and carefully.

BG Българската версия на инструкциите за инсталация и информация за безопасност могат да бъдат намерени на следния адрес: <https://products.currentbyge.com/eu>

CS Návod k montáži a bezpečnostní informace v češtině najdete zde: <https://products.currentbyge.com/eu>

DA Den danske version af installationsvejledningen og sikkerhedsoplysninger kan findes på følgende placering: <https://products.currentbyge.com/eu>

DE Die deutsche Version der Installationsanleitung und Sicherheitsinformationen finden Sie in folgendem Verzeic: <https://products.currentbyge.com/eu>

EL Μπορείτε να βρείτε την ελληνική εκδοχή των οδηγιών εγκατάστασης και των πληροφοριών ασφάλειας στην εξής τοποθεσία: <https://products.currentbyge.com/eu>

ES La versión española de las instrucciones de instalación y la información sobre seguridad puede encontrarse en la siguiente ubicación: <https://products.currentbyge.com/eu>

ET Eestikeelse paigaldusjuhendi ja ohutusnõuded leiate aadressilt: <https://products.currentbyge.com/eu>

FI Asennusohjeiden ja turvallisuustietojen suomenkielinen versio löytyy seuraavasta paikasta: <https://products.currentbyge.com/eu>

FR La version française des instructions d'installations et information de sécurité est disponible à l'adresse suivante: <https://products.currentbyge.com/eu>

HR Hrvatska verzija priručnika za ugradnju i sigurnosnih informacija nalazi se na sljedećoj lokaciji: <https://products.currentbyge.com/eu>

HU A telepítési útmutató és a biztonság információk magyar nyelvű változata az alábbi címen található: <https://products.currentbyge.com/eu>

IT La versione italiana del manuale di installazione e sicurezza può essere reperita nella seguente sezione: <https://products.currentbyge.com/eu>

LT Lietuvišką diegimo instrukcijos ir saugos informacijos versiją galima rasti šioje vietoje: <https://products.currentbyge.com/eu>

LV Uzstādīšanas instrukciju un drošības informāciju latviešu valodā var atrast šeit: <https://products.currentbyge.com/eu>

NL De Nederlandse versie van de installatie-instructies en veiligheidsinformatie kan op de volgende locatie worden gevonden: <https://products.currentbyge.com/eu>

PL Polską wersję instrukcji instalacji oraz informacje dotyczące bezpieczeństwa można znaleźć w następującej lokalizacji: <https://products.currentbyge.com/eu>

PT A versão em Português das instruções de instalação e das informações de segurança pode ser encontrada no seguinte localização: <https://products.currentbyge.com/eu>

RO Versiunea în limba română a instrucțiunilor de instalare și a informațiilor de siguranță pot fi găsite la: <https://products.currentbyge.com/eu>

SV Ni hittar den svenska versionen av installationsanvisningarna och säkerhetsinformationen på följande plats: <https://products.currentbyge.com/eu>

SL Previdnostna opozorila in varnostne informacije so na zadnji strani vodnika za namestitve. Pred začetkom namestitve izdelka jih skrbno preberite: <https://products.currentbyge.com/eu>

SK Slovenskú verzii montážnej príručky a bezpečnostných instrukcií nájdete na nasledujúcej lokalite: <https://products.currentbyge.com/eu>

For the latest North American install guides for your product go to: <https://products.gecurrent.com/led-signage-lighting>

For the latest European install guides for your product go to: <https://products.gecurrent.com/eu/led-signage-lighting>

Prepare Electrical Wiring **FOR UL ONLY**



Electrical Requirements

- Limited to use in dry and damp locations.
- The grounding and bonding of the LED Driver shall be done in accordance with National Electric Code (NEC) Article 600.
- Follow all National Electric Codes (NEC) and local codes.
- These products are only suitable for connection to a circuit from a Class 2 power source. These products have not been evaluated for use when connected to a power source that does not comply with Class 2 voltage and energy limited supplies.

Save These Instructions

Use only in the manner intended by the manufacturer. If you have any questions, contact the manufacturer.



RETROFIT SIGN CONVERSION LED KIT FOR USE ONLY IN ACCORDANCE WITH KIT INSTRUCTIONS.

KIT IS COMPLETE ONLY WHEN ALL PARTS REQUIRED BY THE INSTRUCTIONS ARE PRESENT.

TROUSSE DE CONVERSION À DEL POUR LA MODERNISATION DES ENSEIGNES

À UTILISER CONFORMÉMENT AU GUIDE D'INSTALLATION.

⚠ WARNING / AVERTISSEMENT**RISK OF ELECTRIC SHOCK**

- Turn power off before inspection, installation or removal.
- Properly ground GE power supply enclosure.

RISK OF FIRE

- Use only suitably approved wire for input/output connections. Minimum size 18 AWG (0.82mm²)
- Follow all local codes.
- Not to be submerged or used in a marine environment.

RISQUES DE DÉCHARGES ÉLECTRIQUES

- Coupez l'alimentation avant l'inspection, l'installation ou le déplacement.
- Assurez-vous de correctement mettre à terre l'alimentation électrique GE.

RISQUES D'INCENDIE

- N'utilisez que des fils approuvés par UL pour les entrées/sorties de connexion. Taille minimum 18 AWG (0.82mm²)
- Respectez tous les codes locaux.
- Ne pas submerger ou installer dans un environnement marin.

⚠ UL WARNING / AVERTISSEMENT UL**RISK OF FIRE OR ELECTRIC SHOCK**

- LED Retrofit Kit installation requires knowledge of sign electrical systems. If not qualified, do not attempt installation. Contact a qualified electrician.
- Install this kit only in host signs that have been identified in the installation instructions and where the input rating of the retrofit kit does not exceed the input rating of the sign.
- Installation of this LED retrofit kit may involve drilling or punching of holes into the structure of the sign. Check for enclosed wiring and components to avoid damage to wiring and electrical parts.
- Do not make or alter any open holes in an enclosure of wiring or electrical components during kit installation.

RISQUE D'INCENDIE OU DE CHOC ÉLECTRIQUE

- L'installation de l'équipement de remplacement DEL exige la connaissance des systèmes électriques pour enseignes. Si non qualifié, ne tentez pas d'installation. Veuillez contacter un électricien qualifié.
- Risque d'incendie ou de choc électrique. Installez cet ensemble seulement dans des enseignes hôtes qui ont été identifiés dans les instructions d'installation et dont la capacité d'entrée de l'ensemble ne dépasse pas la capacité d'entrée de l'enseigne.
- L'installation de cet équipement de remplacement DEL peut impliquer le perçage ou le poinçonnage de trous dans la structure du panneau. Vérifiez le câblage et les composants inclus pour éviter d'endommager le câblage et les composants électriques.
- Ne pas faire ou modifier les trous ouverts dans une enceinte de câblage ou de composants électriques pendant l'installation de cet équipement de remplacement DEL.

⚠ CAUTION / ATTENTION**RISK OF INJURY**

- While performing installations described, gloves, safety glasses or goggles should be worn.

RISQUE DE BLESSURE

- Lors de l'exécution des installations décrites, des gants, des lunettes de sécurité ou des lunettes de protection doivent être portées.

This device complies with part 15 of the FCC Rules. Operation is subject to the following two conditions: (1) This device may not cause harmful interference, and (2) this device must accept any interference received, including interference that may cause undesired operation.

Note: This equipment has been tested and found to comply with the limits for a Class A digital device, pursuant to part 15 of the FCC Rules. These limits are designed to provide reasonable protection against harmful interference when the equipment is operated in a commercial environment. This equipment generates, uses, and can radiate radio frequency energy and, if not installed and used in accordance with the instruction manual, may cause harmful interference to radio communications. Operation of this equipment in a residential area is likely to cause harmful interference in which case the user will be required to correct the interference at his own expense.

This Class [A] RFLD complies with the Canadian standard ICES-005. Ce DEFR de la classe [A] est conforme à la NMB-005 du Canada.

Components

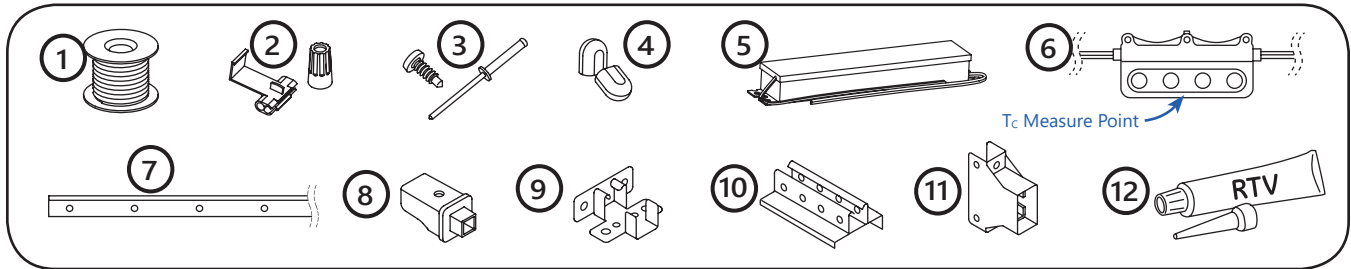

- ① UL certified 18 AWG (0.82 mm²) supply wire
- ② UL certified 22-14 AWG (0.33-2.08 mm²) wire connectors or 18-14 AWG (0.82-2.08 mm²) inline/IDC connectors
- ③ #6 and #8 x 0.50 inch (M3 and M4 x 13mm) self-tapping screws or 1/8" rivets
- ④ Wire end caps
- ⑤ Tetra® 24 VDC Power Supply
- ⑥ Tetra® PowerStrip Snap DS

Optional

- ⑦ Tetra® Snap 8ft. Rail (GEDSRL08-3)
- ⑧ Tetra® Snap Socket Endcap (GEDSSE-3)
- ⑨ Tetra® Snap Frame Endcap (GEDSFE-3)
- ⑩ Tetra® Snap Interconnector (GEDSIC-3)
- ⑪ Tetra® Snap T-Connector (GEDSTC-3)
- ⑫ Electrical grade RTV silicone.

Example electrical grade RTV silicones include:

- Momentive RTV 6700 Series Silicone Rubber Adhesive Sealant
- Momentive White Blanc RTV 162 Silicone Rubber Adhesive Sealant-Electrical Grade
- Dow Corning 3140 - Non-Corrosive Flowable (clear)
- Dow Corning 3145 - Non-Corrosive Nonflowable (clear or gray)
- Dow Corning RTV 748 Non-Corrosive Sealant-White

Installation Using Tetra® Snap Rails

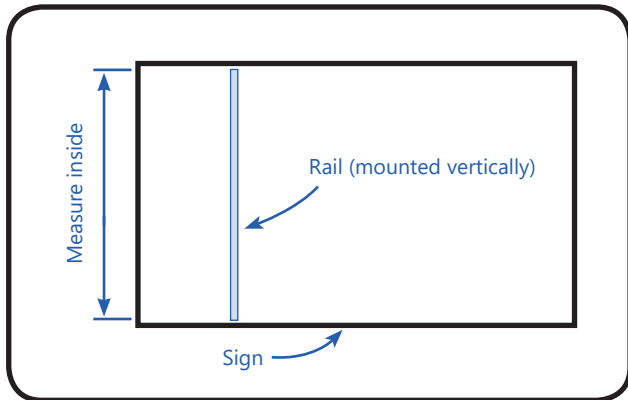

- 1 Measure and cut Tetra® Snap Rail to appropriate length to fit into sign. For retrofitting a sign, see page 6.

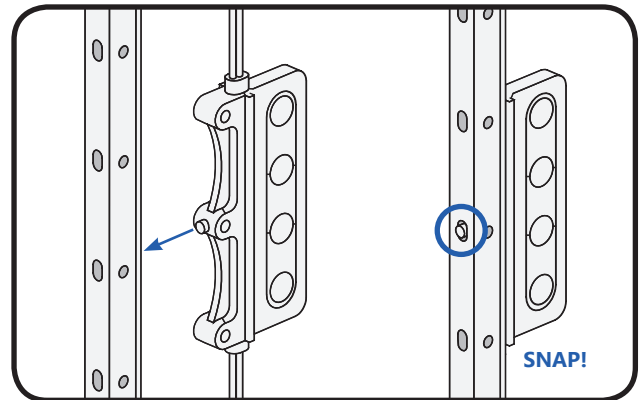

- 2 Align peg on top of the light module with hole on top of the Tetra® Snap Rail and push module into rail until it snaps into place. For added security, fasten module to rail with a screw.

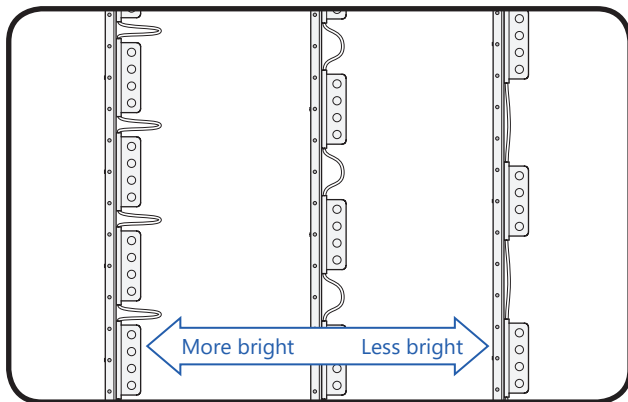

- 3 Evenly space modules across the Tetra® Snap Rail. Different brightness levels can be achieved depending on module spacing.

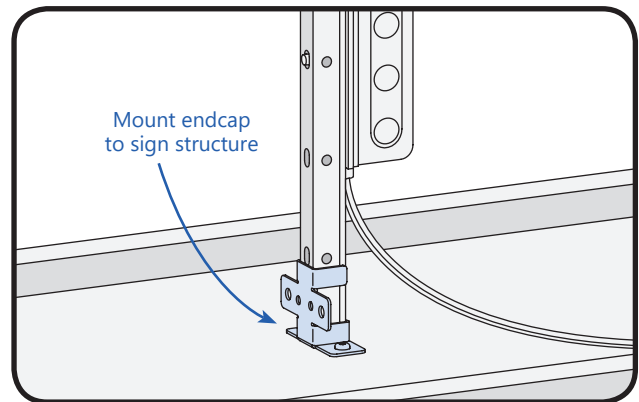

- 4 Secure the Tetra® Snap Rail to the inside of the box sign using the standard Tetra® Snap Frame Endcaps or other suitable means.

Installation Options

Alternative Mounting

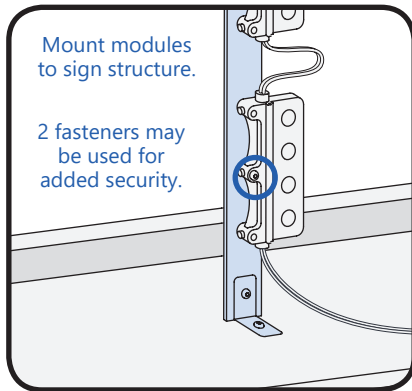

The modules may be attached to any structural member of the sign using one #6 or M3 screw or 1/8" rivet. Ensure the module's lip is tight against rail.

NOTE: Modules may be damaged by improperly sized screws or over-torquing. Screw must be at least 0.75 inches long.

Using Tetra® Snap T-Connectors

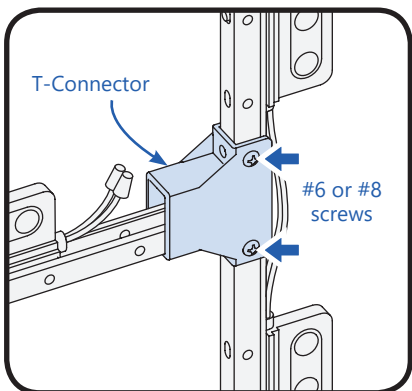

Use a Tetra® Snap T-Connector to join rails perpendicular to each other.

Use #6 or #8 screw to attach T-Connector to side of rail.

NOTE: T-Connector must be secured with screws to the mounting rail.

Using Tetra® Snap Interconnectors

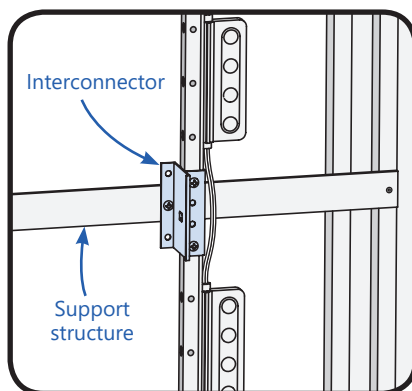

Use a Tetra® Snap Interconnector to join two rails and create longer runs.

NOTE: Runs must be secured with screws to supporting structure at intervals no greater than 8 feet (2.43 m).

Using Tetra® Snap Socket Endcap

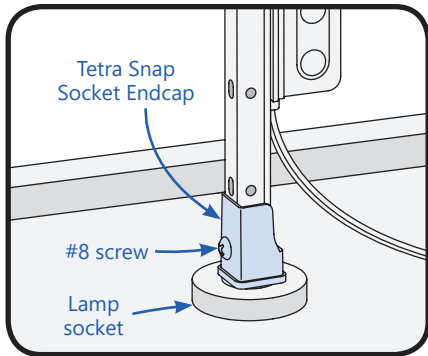

When retrofitting a sign, ensure the rail is cut to the appropriate length to properly seat in the lamp socket, and use Tetra® Snap Socket Endcaps to secure rails to existing lamp sockets.

NOTE: When utilized, ensure the rail is properly seated in the lamp sockets. For horizontal installations greater than 5 ft. in length, the rail assembly should be centrally supported.

Tetra® Snap Nominal LFL Rail Length Requirements

Nominal T12 Tube Length	Nominal Rail Cut Length
1.5 ft.	15" (381.5mm)
2 ft.	21" (533.1mm)
2.5 ft.	27" (685.8mm)
3 ft.	33" (837.9mm)
3.5 ft.	39" (990.6mm)
4 ft.	45" (1142.7mm)
5 ft.	57" (1447.5mm)
5.33 ft.	61" (1549.5mm)
6 ft.	69" (1752.3mm)
7 ft.	81" (2057.1mm)
8 ft.	93" (2361.9mm)

Retrofit Instructions **FOR UL ONLY**

- (Existing Signs Only)** Prior to installation, survey the site for information regarding power and accessibility inside and outside the building. Ensure that the branch circuit supplying the existing transformer or ballast will be within the voltage ratings of the new LED power supply, and have a current rating not exceeding 20A, or that permitted by applicable local, state, or country electrical codes (whichever is less).
- (Existing Signs Only)** Remove the existing lighting equipment to be replaced, such as neon tubing or fluorescent tubes; and associated transformers and ballasts. Care should be taken not to break the existing neon or fluorescent tubes. **NOTE:** Follow all federal and local regulations when disposing of neon tubing, fluorescent tubes, transformers and ballasts.
- (Existing Signs Only)** If removal of the existing lighting equipment eliminates the disconnect switch, as required by applicable local, state, or country electrical codes; a new disconnect switch must be installed.
- (Existing Signs Only)** Repair and seal any unused openings in the electrical enclosure. Openings greater than 12.7-mm (1/2-in) diameter require a metal patch secured by screws or rivets and caulked with non-hardening caulk. Smaller openings may be sealed with non-hardening caulk.
- Using the layout guidelines above, determine required number of LED modules required to illuminate the sign.
- A Tetra® 24VDC Class 2 Power Supply, as listed below, must be used with this retrofit kit. Using the Maximum Loading chart below, determine the number of Tetra® Class 2 Power Supplies required to power the number of LED modules required to illuminate the sign, so as not to overload the Tetra® Class 2 Power Supply chosen.
- Follow the instructions above to properly mount the LED modules.
- Connect the DC output of the power supply to the LED modules using the Electrical Connections instructions below.
- Connect the power unit to the supply in accordance with the applicable local, state, and country electrical codes, and the instructions found in the power supply installation guide.
- If required, the disconnect switch shall be installed by qualified personnel, in accordance with applicable local, state, and country electrical codes.

Electrical Connections

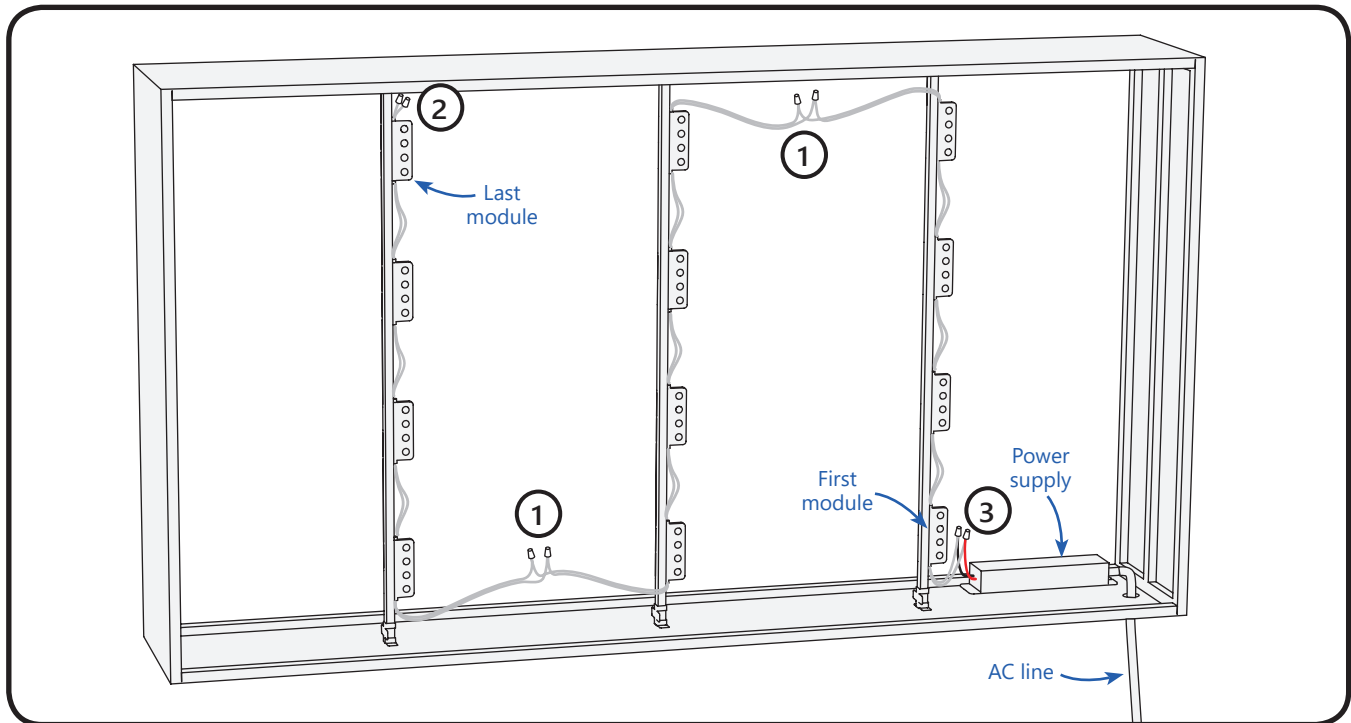

① Connect modules using twist-on wire connectors or in-line (IDC) connectors. Join white wires together and red striped wires together.

② Cap all exposed wires with appropriate end caps or apply electric grade (non-corrosive) silicone for additional weather protection.

③ Connect output side of power supply to first module. Connect the red stripe wire (+) of the LED system to the red wire (+) of the power supply. Connect the white wire (-) of the LED system to the black or blue wire (-) of the power supply. Connect AC line to input side of power supply.

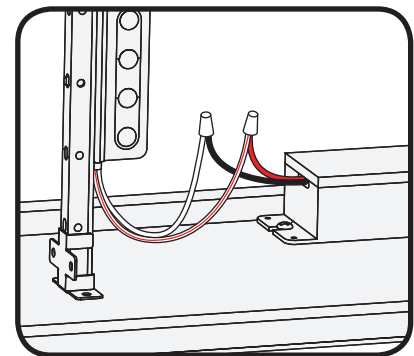

NOTES:

- Exceeding maximum load will cause the power supply to shut down. If overload occurs, remove excess load, recycle the input power to restart the power supply.
- All electrical connections should be suitably protected from mechanical damage and the environment. Seal all connections in locations that may be exposed to water with electrical grade RTV silicone. See page 3 for recommended silicones.
- Must be used with **Tetra® 24 Volt Power Supplies**.
- Additional supply wire may be necessary to bridge electrical connections.
- Wire nuts should be facing up so as not to collect water.

Troubleshooting

Symptom	Solution
Row of modules does not light	<ul style="list-style-type: none"> • Check wire connections to power supply to ensure red stripe-to-red and white-to-black or blue connections. • Check row-to-row polarity connections.
Sign does not light	<ul style="list-style-type: none"> • Check input and output voltage and check power supply input/output connections. • Check polarity connections. • Ensure the overall length of the Tetra® LED System does not exceed the maximum load.
Individual modules do not light	<ul style="list-style-type: none"> • Remove module and replace with another working module.
Modules are dim	<ul style="list-style-type: none"> • Ensure the overall length of the Tetra® LED system does not exceed the maximum load. • Ensure the length and gauge of the supply wire is equal to or below the recommended remote mounting distance.

Maximum Loading per Tetra® 24 VDC Class 2 Power Supply

SKU	Rating	25W	80W	100W	180W	300W
		Power Supply <i>Note: Load shall not exceed 1.04A</i>	Dimming Power Supply <i>Note: Load shall not exceed 3.3A</i>	Power Supply <i>Note: Load shall not exceed 4.0A</i>	Power Supply <i>Note: Load shall not exceed 4A per each (of 2) output channels</i>	Power Supply <i>Note: Load shall not exceed 4A each (of 3) output channels</i>
GEDS71-3	24VDC 2.59W/module	8 modules	26 modules	32 modules	29 modules per output channel 58 modules per power supply	32 modules per output channel 96 modules per power supply
GEDS65-3						
GEDS57-3						
GEDS50-3						
GEDS41-3						
GEDS32-3						

Maximum Remote Mounting Distance

	18 AWG/0.82 mm ² Supply Wire	16 AWG/1.31 mm ² Supply Wire	14 AWG/2.08 mm ² Supply Wire	12 AWG/3.31 mm ² Supply Wire
25W Power Supply	120 ft./36.6 m	-	-	-
80W Power Supply	20 ft./6.1 m	25 ft./7.6 m	35 ft./10.6 m	40 ft./12.1 m
100W Power Supply	20 ft./6.1 m	25 ft./7.6 m	35 ft./10.6 m	40 ft./12.1 m
180W Power Supply	20 ft./6.1 m	25 ft./7.6 m	35 ft./10.6 m	40 ft./12.1 m
300W Power Supply	20 ft./6.1 m	25 ft./7.6 m	35 ft./10.6 m	40 ft./12.1 m

If you have any questions about these instructions or your specific application, please contact support at tetra.support@gecurrent.com.

This product is intended solely for the use of non-residential signage lighting and is not intended for use in any other applications.

Conforms to the following standards: IP66.

LED modules are not suitable for prolonged submersion or direct exposure to water and must be protected from the weather.

Acceptable for use in dry and damp locations

The suitability of rain enclosure shall be determined if intended for wet location.

